

A	B	C	Wgt.KG
1515	700	100	580

Size in MM

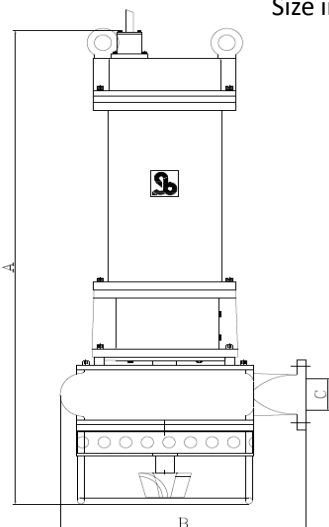

Series	Model	HP /kw	Outlet size in MM
100 - 350	SBSL504	50 / 30	100

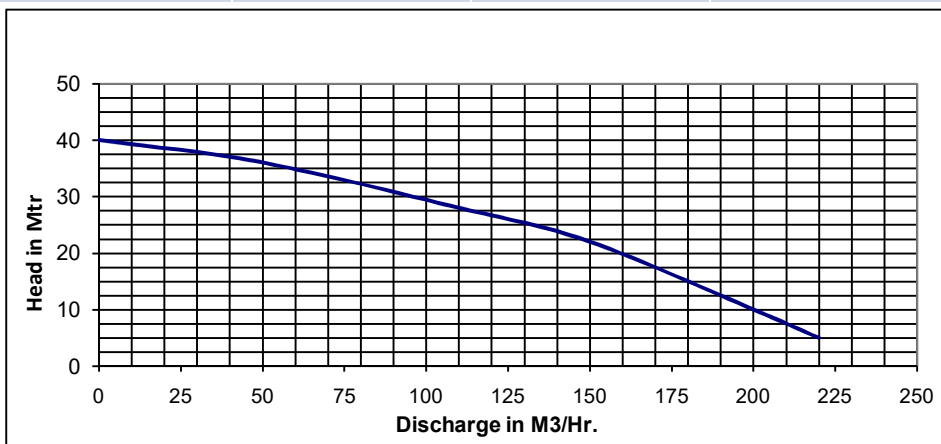

Pump type	Submersible Slurry Pump	
Motor	Type	Induction Motor
	Poles	4
	Insulation	F Class (H on request)
	Starting Method	DOL
	Volts	415 +/-10%
	Phase	3
	Protection	IP68
	Speed	1450 RPM
Full Load Current	67 Amp.	
Lubricants Bearings	Grease	
Lubricants Seals	Food Grade Oil	
Mechanical Seal	Double	Silicon Vs Silicon
Liquid Density (Max.)	2.5 Kg/Ltr	
Solid Size in MM	Max.	40
Ph Ranges	5 to 8	
Cable	Double Sheathed copper 10 Mtr. Extra on request	
Max. Submergence	20 Mtr.	
Mini.Submergence	200MM Below water level.	
Max.liquid Temp	45 Deg. Centi.*Higher on Request	
Material of Construction	Impeller	Hi - Chrome
	Housings	Cast Iron Grd.Fg 260
	Stator Body	Cast Iron Grd.Fg 260
	Casing	SG IRON
	Rotor Shaft	SS431
	Rubber Parts	Nitrile Rubber
	Hardware	SS 304

Due to continuous product development, specifications are subject to change without notice
*Other Material of Construction on Request.

*Inbuilt Thermister